

8 7 6 5 4 3 2 1

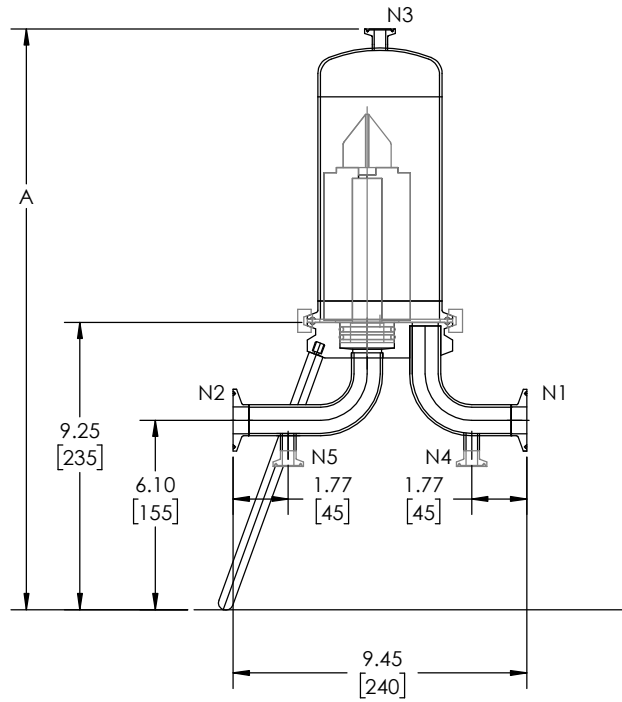
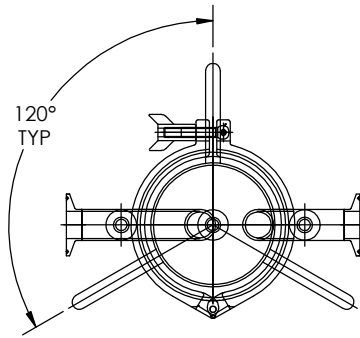

△ B

TABULATION			
PART NO.	DESCRIPTION	GLOBAL FILTER MODEL NO.	DIMENSION A inches [mm]
21289-01	FLTR HSG ASSY, GSTL 1" TC, 222, 5" 304 SS		18.70 [475]
21289-02	FLTR HSG ASSY, GSTL 1" TC, 222, 5" 316 SS	GSTL051T2615EP	18.70 [475]
21289-03	FLTR HSG ASSY, GSTL 1" TC, 222, 10" 304 SS		23.62 [600]
21289-04	FLTR HSG ASSY, GSTL 1" TC, 222, 10" 316 SS	GSTL11T2615EP	23.62 [600]
21289-05	FLTR HSG ASSY, GSTL 1" TC, 222, 20" 304 SS		33.47 [850]
21289-06	FLTR HSG ASSY, GSTL 1" TC, 222, 20" 316 SS	GSTL21T2615EP	33.47 [850]
21289-07	FLTR HSG ASSY, GSTL 1" TC, 222, 30" 304 SS		43.31 [1100]
21289-08	FLTR HSG ASSY, GSTL 1" TC, 222, 30" 316 SS	GSTL31T2615EP	43.31 [1100]
21289-09	FLTR HSG ASSY, GSTL 1" TC, 222, 40" 304 SS		53.15 [1350]
21289-10	FLTR HSG ASSY, GSTL 1" TC, 222, 40" 316 SS	GSTL41T2615EP	53.15 [1350]

NOZZLE SCHEDULE

ITEM	SERVICE	SIZE	QTY	EXTERNAL FLANGE DIMENSION
N1	INLET	1"	1	ASME BPE V BAND CLAMP CONNECTION
N2	OUTLET	1"	1	ASME BPE V BAND CLAMP CONNECTION
N3	AIR VENT	1/2"	1	ASME BPE V BAND CLAMP CONNECTION
N4	INLET DRAIN	1/2"	1	ASME BPE V BAND CLAMP CONNECTION
N5	OUTLET DRAIN	1/2"	1	ASME BPE V BAND CLAMP CONNECTION

DESIGN DATA

DESIGN CODE	GOOD ENGR. PRACT.
DESIGN PRESS.	150 psi [10.5 Kg/cm <sup>2</sup> ]
WORKING PRESS.	135 psi [9.5 Kg/cm <sup>2</sup> ]
DESIGN TEMP	250° F [121°C]
HYDRO TEST	195 psi [13.7 Kg/cm <sup>2</sup> ]
SUITABLE FOR	222/FIN TYPE CARTRIDGE

REFERENCE ENGINEERING DRAWING 21289

△ B

C		EC210303-01	MATERIAL	<b>GLOBAL FILTER LLC</b> TITLE: FLTR HSG ASSY, GSTL 1" TC, 222, TAB
B		EC210107-01	FINISH	
A		EC201022-01	SEE NOTE 3	
REV	EC NUMBER	DRAWN BY	NAME	DATE
		ENG APPR.	EG	10-27-20

SIZE	DWG. NO.	REV
<b>B</b>	<b>CS268</b>	<b>C</b>
SCALE: 1:1	WEIGHT:	SHEET 1 OF 1

**PROPRIETARY AND CONFIDENTIAL**  
 THE INFORMATION CONTAINED IN THIS DRAWING IS THE SOLE PROPERTY OF GLOBAL FILTER LLC. ANY REPRODUCTION IN PART OR AS A WHOLE WITHOUT THE WRITTEN PERMISSION OF GLOBAL FILTER LLC IS PROHIBITED.

△ C

- NOTES:
- DIMENSIONS ARE IN INCHES [millimeters].
  - UNLESS TOLERANCES ARE INDICATED, ALL DIMENSIONS ARE REFERENCE.
  - SURFACE FINISH:
    - INSIDE: MIRROR POLISH WITH EP <25 µin Ra (<0.63 µm Ra)
    - OUTSIDE: MIRROR POLISH <25 µin Ra (<0.63 µm Ra)

8 7 6 5 4 3 2 1