

TABULATION		
PART NO.	DESCRIPTION	GLOBAL FILTER MODEL NO.
CS076-01	FLTR HSG ASSY, GMBV4 SER 4" FLG, 304 SS	GMBV4304F415GB
CS076-02	FLTR HSG ASSY, GMBV4 SER 4" FLG, 304 SS, CODE	GMBV4304F415GBU
CS076-03	FLTR HSG ASSY, GMBV4 SER 4" FLG, 316 SS	GMBV4304F615GB
CS076-04	FLTR HSG ASSY, GMBV4 SER 4" FLG, 316 SS, CODE	GMBV4304F615GBU
CS076-05	FLTR HSG ASSY, GMBV4 SER DIN 100, 304 SS	GMBV430100D415GB
CS076-06	FLTR HSG ASSY, GMBV4 SER DIN 100, 304 SS, CODE	GMBV430100D415GBU
CS076-07	FLTR HSG ASSY, GMBV4 SER DIN 100, 316 SS	GMBV430100D615GB
CS076-08	FLTR HSG ASSY, GMBV4 SER DIN 100, 316 SS, CODE	GMBV430100D615GBU

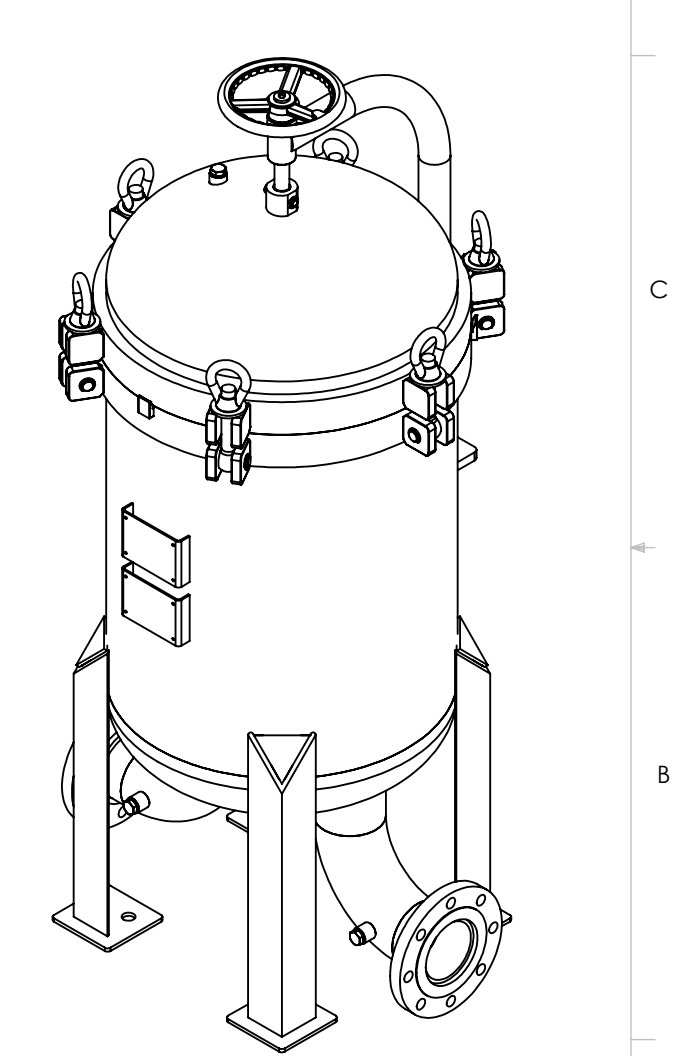
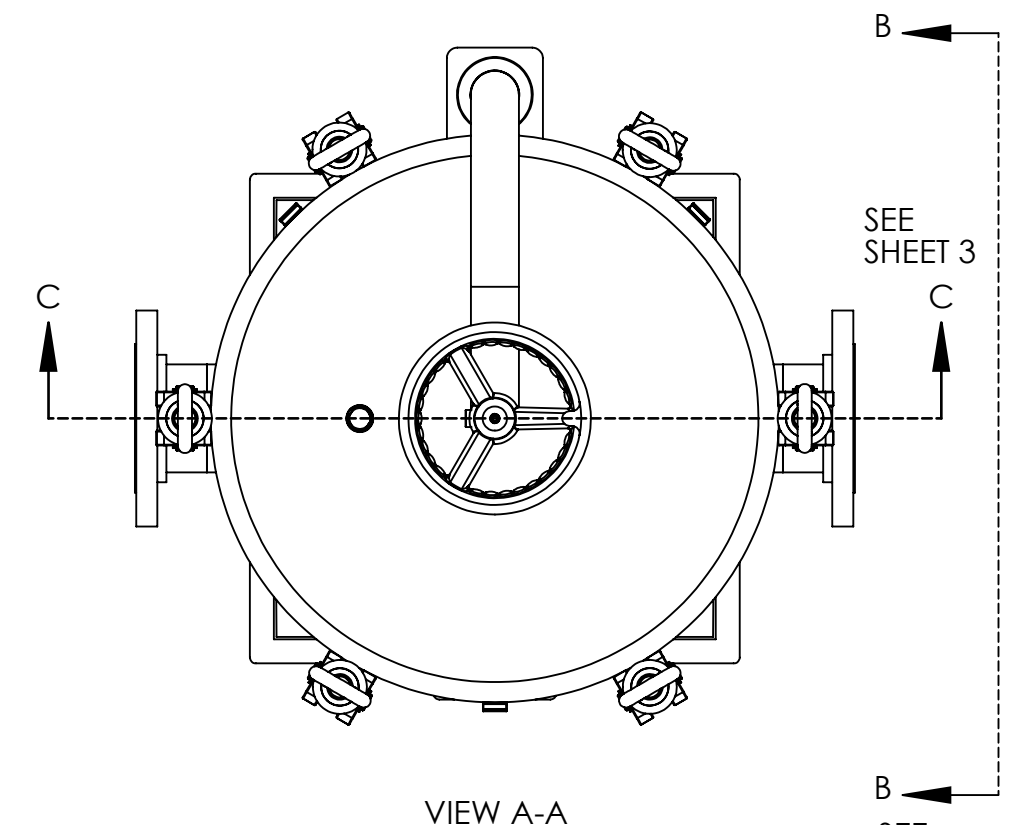

SHIPPING WEIGHT AND SIZE MAY DIFFER FROM STATED VALUES DUE TO PALLETIZING AND QUANTITY CONSIDERATIONS

VESSEL SIZE	BOXED WEIGHT (LBS)	BOX SIZE (INCHES)
SIZE 2	650	45 x 48 x 74

REFERENCE ENGINEERING DRAWING 21062

- NOTES:
- SEE SHEET 2 FOR BILL OF MATERIALS.
 - ALL MODELS COMPLY WITH REQUIREMENTS FOR DESIGN AND CONSTRUCTION IN ACCORDANCE WITH THE ASME BOILER & PRESSURE VESSEL CODE, SECTION VIII, DIVISION 1. MODELS BEARING THE "U" OR "UM" STAMP ARE REGISTERED WITH THE NATIONAL BOARD OF BOILER AND PRESSURE VESSEL INSPECTORS.
 - ASME CODE STAMPED VESSELS WILL HAVE TWO NAME PLATE BRACKETS, NON-CODE STAMPED VESSELS WILL HAVE ONE NAME PLATE BRACKET.

PROPRIETARY AND CONFIDENTIAL
 THE INFORMATION CONTAINED IN THIS DRAWING IS THE SOLE PROPERTY OF GLOBAL FILTER LLC. ANY REPRODUCTION IN PART OR AS A WHOLE WITHOUT THE WRITTEN PERMISSION OF GLOBAL FILTER LLC IS PROHIBITED.

REV	EC NUMBER	MATERIAL	FINISH	DRAWN BY	NAME	DATE
C	EC180719-02	SEE TABULATION TABLE	GLASS BEAD	ME	EG	10-1-14
B	EC180429-01					
A	EC140926-01					
EC HISTORY			ENG APPR.	EG	10-2-14	

GLOBAL FILTER LLC

TITLE: **FLTR HSG ASSY, GMBV430 SER 4"/DIN 100 FLG, TAB**

SIZE B	DWG. NO. CS076	REV C
SCALE: 1:8	WEIGHT:	SHEET 1 OF 3

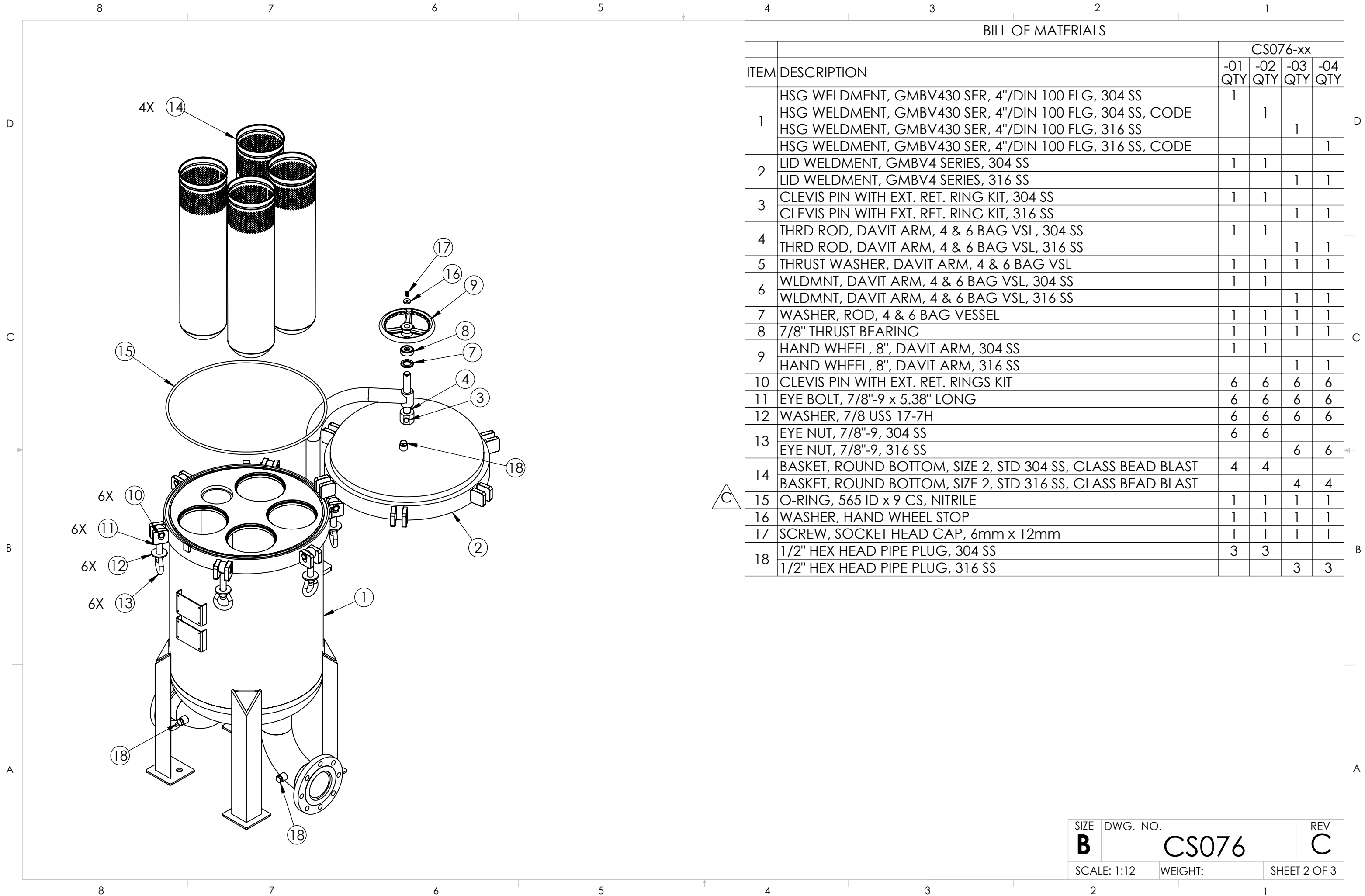

BILL OF MATERIALS

ITEM	DESCRIPTION	CS076-xx			
		-01 QTY	-02 QTY	-03 QTY	-04 QTY
1	HSG WELDMENT, GMBV430 SER, 4"/DIN 100 FLG, 304 SS	1			
	HSG WELDMENT, GMBV430 SER, 4"/DIN 100 FLG, 304 SS, CODE		1		
	HSG WELDMENT, GMBV430 SER, 4"/DIN 100 FLG, 316 SS			1	
	HSG WELDMENT, GMBV430 SER, 4"/DIN 100 FLG, 316 SS, CODE				1
2	LID WELDMENT, GMBV4 SERIES, 304 SS	1	1		
	LID WELDMENT, GMBV4 SERIES, 316 SS			1	1
3	CLEVIS PIN WITH EXT. RET. RING KIT, 304 SS	1	1		
	CLEVIS PIN WITH EXT. RET. RING KIT, 316 SS			1	1
4	THRD ROD, DAVIT ARM, 4 & 6 BAG VSL, 304 SS	1	1		
	THRD ROD, DAVIT ARM, 4 & 6 BAG VSL, 316 SS			1	1
5	THRUST WASHER, DAVIT ARM, 4 & 6 BAG VSL	1	1	1	1
6	WLDMNT, DAVIT ARM, 4 & 6 BAG VSL, 304 SS	1	1		
	WLDMNT, DAVIT ARM, 4 & 6 BAG VSL, 316 SS			1	1
7	WASHER, ROD, 4 & 6 BAG VESSEL	1	1	1	1
8	7/8" THRUST BEARING	1	1	1	1
9	HAND WHEEL, 8", DAVIT ARM, 304 SS	1	1		
	HAND WHEEL, 8", DAVIT ARM, 316 SS			1	1
10	CLEVIS PIN WITH EXT. RET. RINGS KIT	6	6	6	6
11	EYE BOLT, 7/8"-9 x 5.38" LONG	6	6	6	6
12	WASHER, 7/8 USS 17-7H	6	6	6	6
13	EYE NUT, 7/8"-9, 304 SS	6	6		
	EYE NUT, 7/8"-9, 316 SS			6	6
14	BASKET, ROUND BOTTOM, SIZE 2, STD 304 SS, GLASS BEAD BLAST	4	4		
	BASKET, ROUND BOTTOM, SIZE 2, STD 316 SS, GLASS BEAD BLAST			4	4
15	O-RING, 565 ID x 9 CS, NITRILE	1	1	1	1
16	WASHER, HAND WHEEL STOP	1	1	1	1
17	SCREW, SOCKET HEAD CAP, 6mm x 12mm	1	1	1	1
18	1/2" HEX HEAD PIPE PLUG, 304 SS	3	3		
	1/2" HEX HEAD PIPE PLUG, 316 SS			3	3

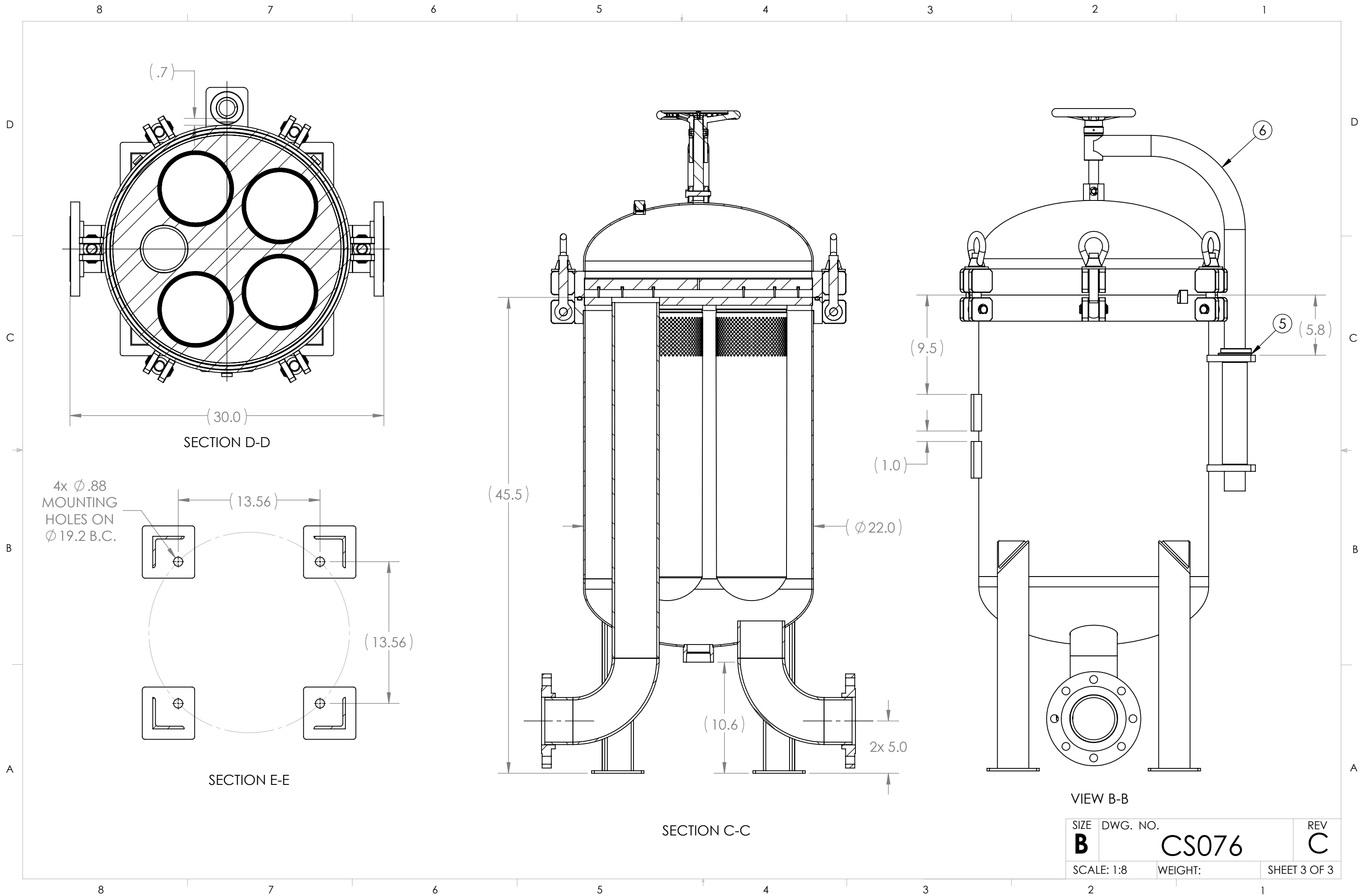

SIZE B	DWG. NO. CS076	REV C
SCALE: 1:8	WEIGHT:	SHEET 3 OF 3